

AIR CURTAIN SENSOR

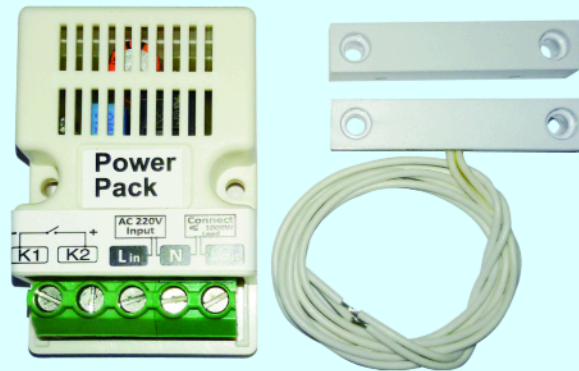

ELECTRICAL SPECIFICATIONS:

Input Voltage: 220V AC

Sensing Output Voltage : 2 wire type, to be attached to Magnetic

Switch NO type Model PS 910 MNO

Load Output : 220V AC, 15Amp

CONNECTION DIAGRAM:

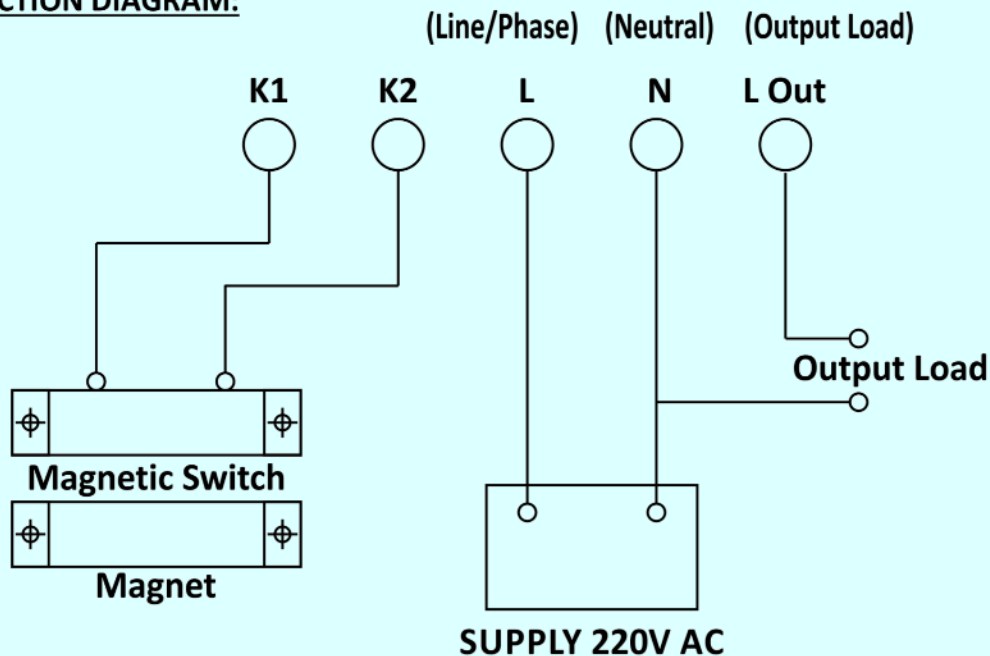

MAGNETIC SWITCH SPECIFICATIONS:

Part No.: PS 910 MNO

Normally Open Contact Switch (NO, 1 Form A)

ELECTRICAL SPECIFICATIONS:

Contact Rating	:	10W/VA
Switching Voltage (Max.)	:	200 VDC
Switching Current (Max.)	:	0.5 Amp.
Contact Resistance (Min.)	:	200 milli ohms
Life Expectancy	:	1.0 Million Operations
Insulation Resistance	:	10 ⁹ ohms
Shock Resistance	:	30G for 11mSec.
Vibration Resistance	:	20G (10 to 1000Hz)
Magnets	:	ALINCO/ Rare Earth (Unless otherwise specified)